



GUN DRILLS
the complete program



HARTNER

Precision Cutting Tools



THE DRILLING PROCESS

A brief introduction to the subject of deep hole gun drilling

In the machining world, drilling depths of $10 \times D$ and deeper are regarded as deep hole drilling operations, whereby smaller drilling depths can naturally also be produced with gun drills. Advantage is taken of the positive side effects, as for example good surface quality, low deviation from concentricity and optimised alignment accuracy.

(Figure above right)

Typical procedure with all gun drills on conventional machine tools:

- production of pilot hole. Enter at low revolutions, approx. 200 rev./min, feed rate approx. 500 mm/min.
- setting coolant pressure and speed.
- continuous drilling to complete hole depth without chip removal. When applying gun drills with increased length-diameter-ratio (e.g. single fluted, solid carbide gun drills from flute length 160 mm), we recommend machining with reduced cutting parameters (approx. 75% of the optimal cutting speed) up to a drilling depth of approx. 25 mm.
- switch off coolant supply after reaching hole depth.
- withdrawal in rapid feed with stationary spindle.

High pressure cooling has become a matter of course.

In recent years, internal cooling has established itself for all drilling tools. Coolants are now living up to their name and being supplied via coolant ducts to where they are urgently required.

Considerable improvements in tool life and less breakages have been achieved by this measure for twist drills, taps etc. Every conventional machine tool currently on the market can be supplied with high pressure internal cooling and is therefore also suitable for deep hole drilling.

The share of gun drills on machining centres, lathes etc. is forever gaining more importance. The process is therefore increasing in popularity in the machining world.



All gun drills must have support for the pilot hole.

Gun drills must never operate at full speed without support in the machine shop.

Deep hole drilling is not a closed book, but can be mastered by anybody as long as certain conditions are adhered to.

Recommended cutting rates for the application of Hartner gun drills can be found on the pages for the individual types!

MACHINING CONCEPTS

Schematic diagrams

Deep hole drilling on conventional machine tools

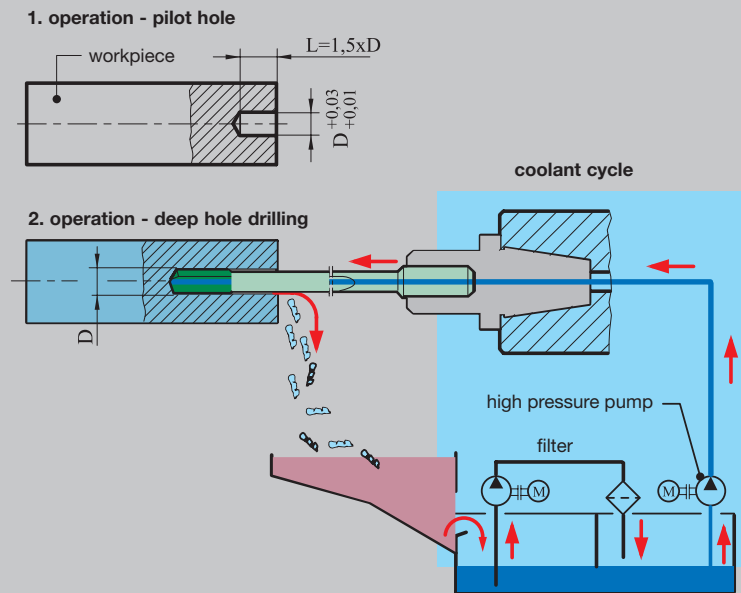

Deep hole drilling on deep hole drilling machines

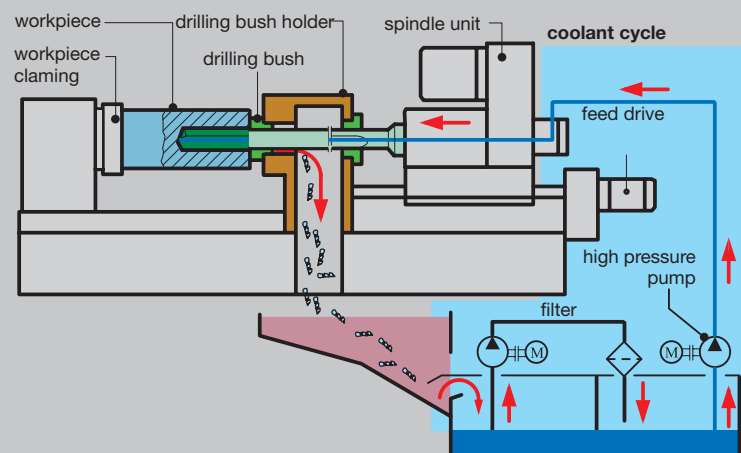

PRECISION

of single-fluted deep hole gun drills

Basic tolerances

The application of single-fluted gun drills can achieve a lower basic tolerance, as the cutting forces at the cutting edge are absorbed by the supporting strips, unlike twist drills where the slightest deviation of the two cutting edges causes a larger hole.

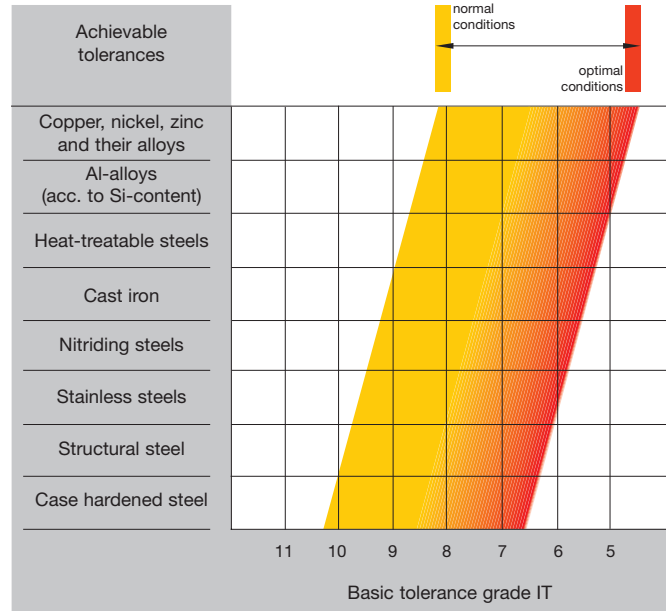

Surface quality

The forces at the cutting edge are absorbed by the support bushes, which in return burnishes the surface. Lubrication between the supporting strips and hole surface is therefore very important.

The better the lubricant, the better the surface quality.

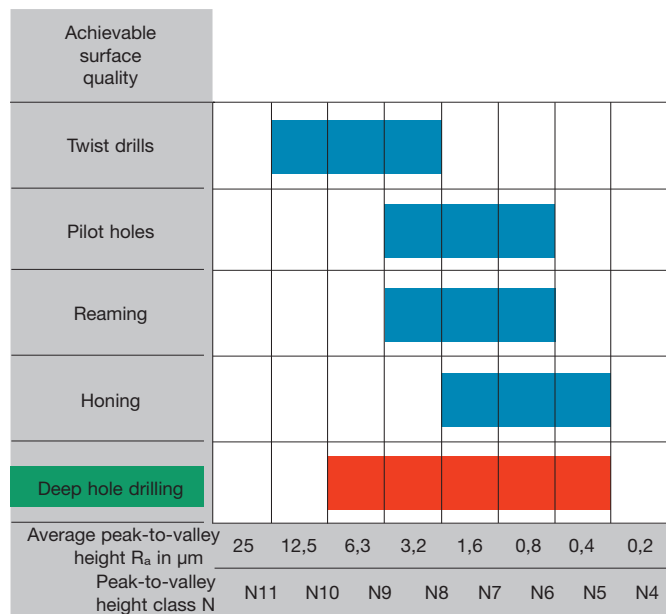

Alignment accuracy

Because brazed single-fluted gun drills always have the precision carbide head brazed onto a flexible tube, the tool achieves very accurate aligned holes remaining unaffected by possible concentricity errors. However, extreme material fluctuations and other influencing factors can impair the alignment accuracy.

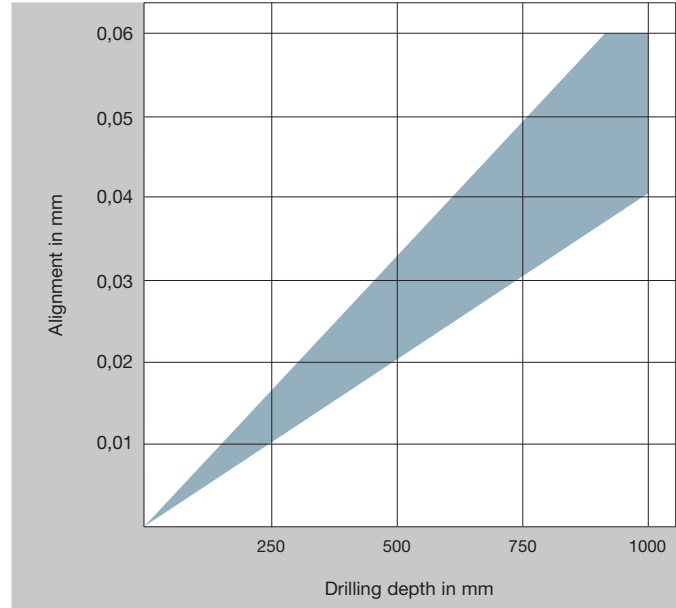

Deviation from concentricity

When a hole is produced with for example, a commercial twist drill, the quality of the point grind affects the concentricity of the hole. An imbalance of forces is created at the cutting edges. With gun drills, these cutting forces are absorbed by the supporting strips, resulting in excellent concentricity.

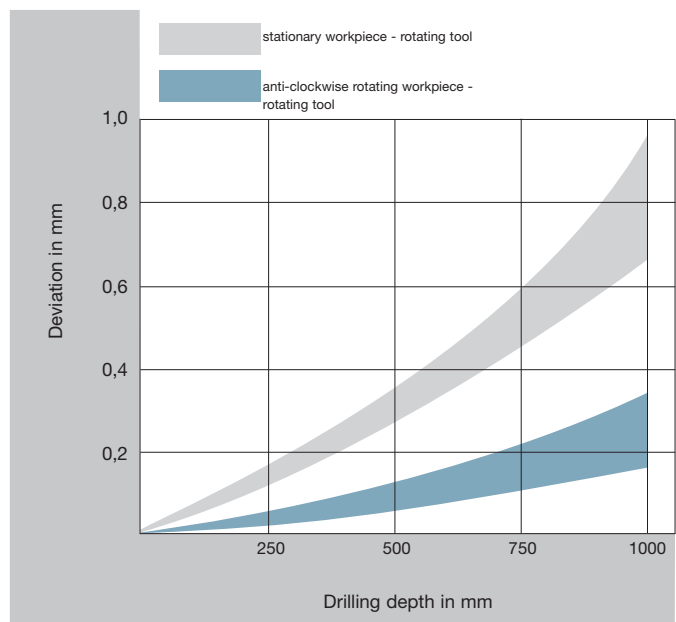

SOLID CARBIDE SINGLE-FLUTED GUN DRILL E 100

suitable for almost every material, from \varnothing 1.2 - 5.0 mm,
max. flute length 300 mm



To ask for or to order Hartner solid carbide single-fluted gun drills E 100 especially suited to your application, please complete the fax inquiry on page 21.

For certain materials a coating is required, as the successful application of gun drills with a bright surface finish cannot be guaranteed. For coating definitions see Hartnerguide.

T TiN-coat
 F FIRE
 M MolyGlide

The dimensions required to calculate the length for conventional machine tools

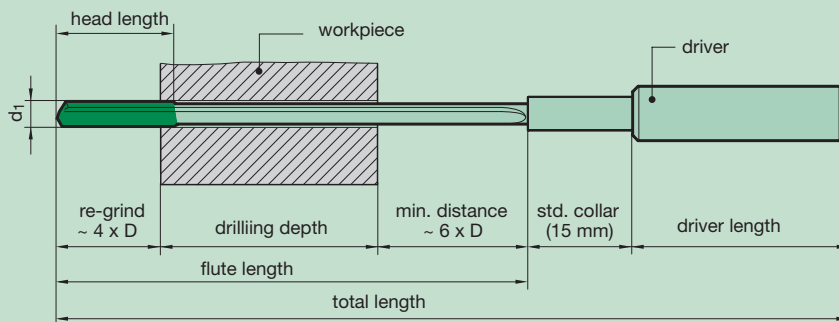

Head forms

(Position of supporting strips. Special head forms on request.)

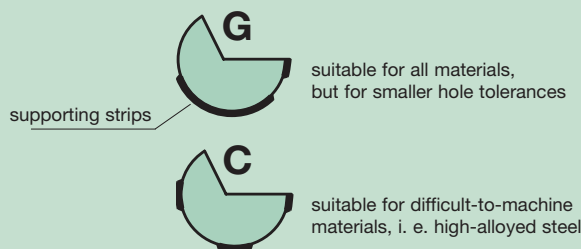

Standard point grinds

(special point grinds on request)

\varnothing 2...4,00 mm

\varnothing > 4,01...20 mm

Back taper ratio 1:800 (standard)
(dimensions in mm)

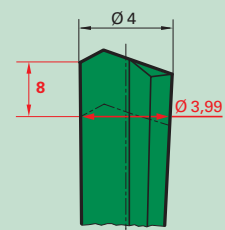
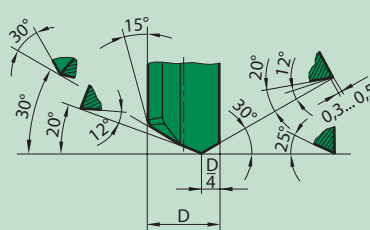
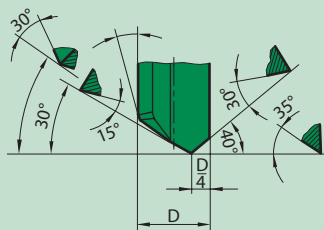

Ex-stock range solid carbide single-fluted gun drills E 100:

- from Ø 1.2 to 5.0 mm
- with flute lengths 45, 80, 120 and 160 mm
- suitable for almost every material
- available within 24 hours
- surface bright
- head form G
- standard point grinds

For prices and technical information please see page 16.

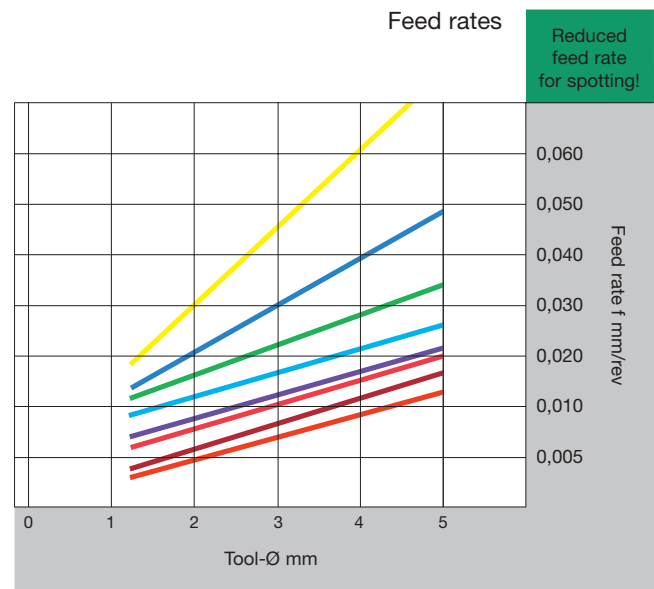
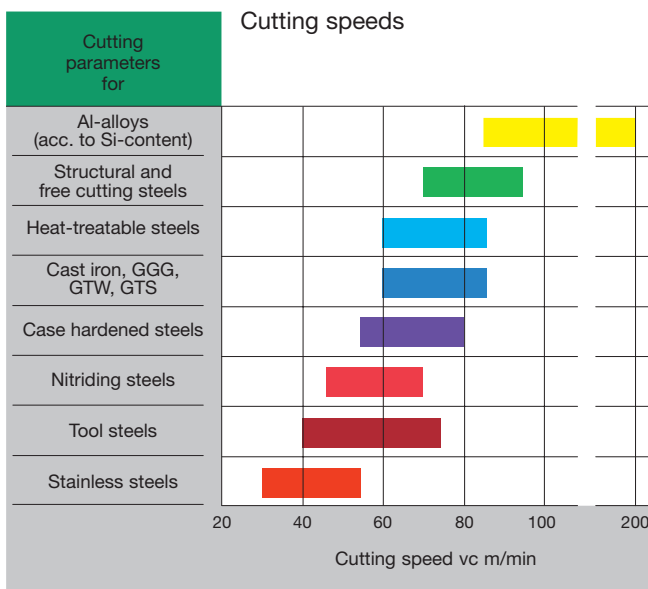

(Detailed cutting parameters see page 22/23)

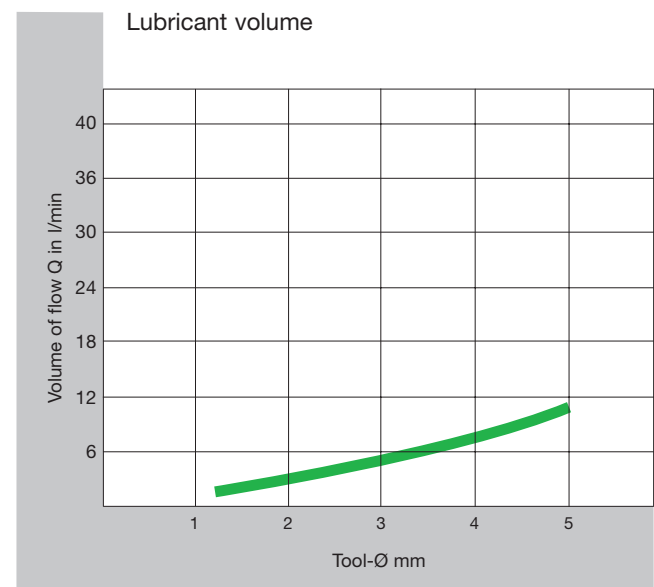
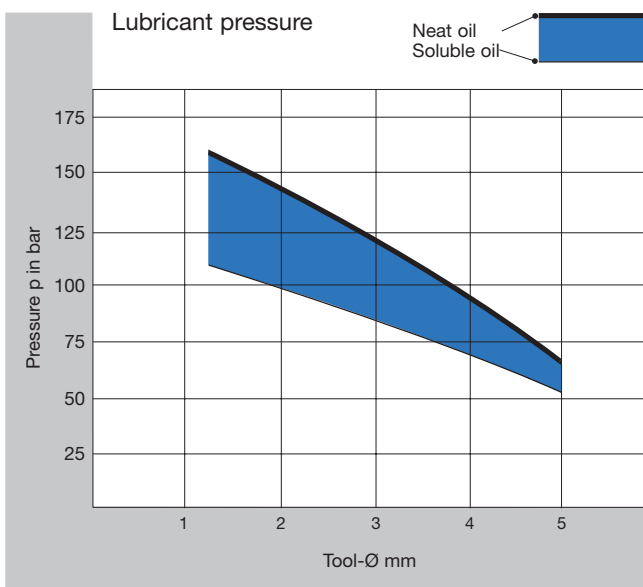

SINGLE-FLUTED GUN DRILLS WITH SOLID CARBIDE HEAD E 80



suitable for almost every material, from Ø 2 - 40.0 mm, max. total length 3000 mm



To ask for or to order Hartner single-fluted gun drills E 80 with solid carbide head especially suited to your application, please complete the fax inquiry on page 21.
From Ø 6.0...20.0 mm we can fit PCD or CBN cutting edges on request.
With AlSi-alloys for example, tool life subsequently increases multi-fold.

For certain materials a coating is required, as the successful application of gun drills with a bright surface finish cannot be guaranteed.
For coating definitions see Hartnerguides.

T TiN-coat **F** FIRE **M** MolyGlide

The dimensions required to calculate the length for conventional machine tools

* max. flute length per tool 40 x D, for larger drilling depths apply two tools. (i.e. Ø 10 x 450 and Ø 9,95 x 850 mm)

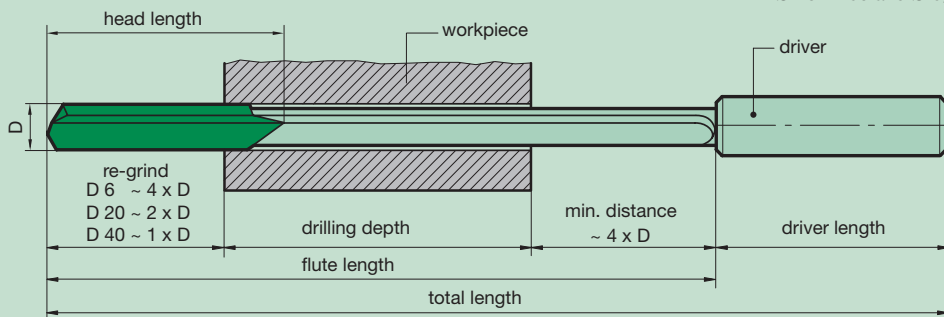

Head forms

(Position of supporting strips.)

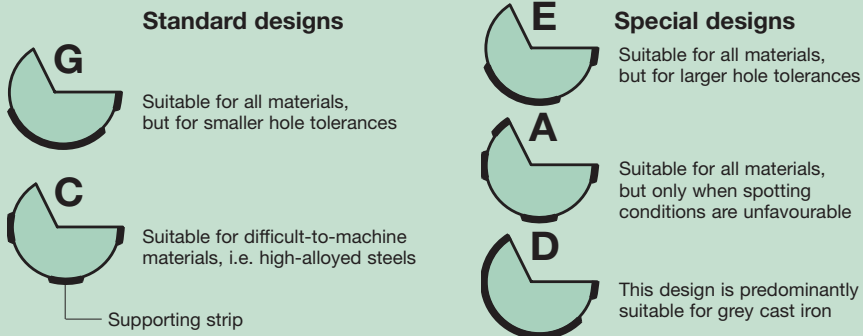

Standard point grinds (special point grinds available, see page 19)

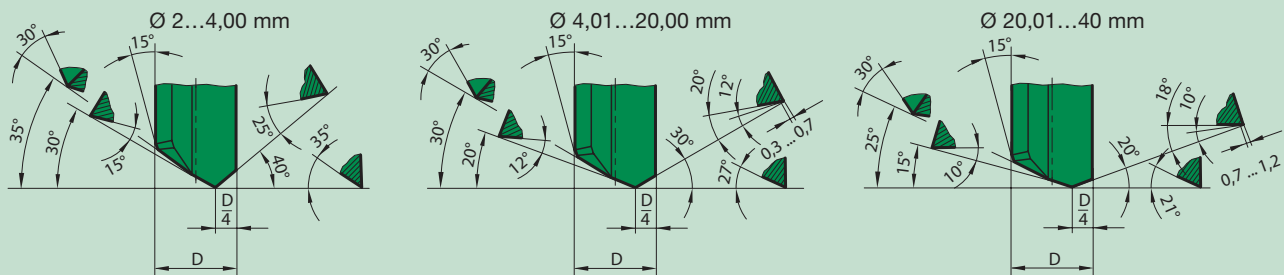

Ex-stock range single-fluted gun drills with solid carbide head E 80:

- Ø 4.0 up to 12.0 mm (preferred dimensions)
- for drilling depths up to 20, 30, 40 and 80 x D
- suitable for demanding applications, e.g.:
 - aluminium or cast iron enlarged coolant chamber
 - stainless steels with soluble oil

- TiN-coated
- head form G
- point grind with chipbreakers and

For prices and technical information see page 17.

Fast service for brazed single-fluted gun drills

In addition to the ex-stock range Hartner offers a fast service for gun drills with standard point grind and standard driver in following dimensions. Delivery time is max. 3 weeks.

nom.-Ø- mm	in increments of mm	head form	total length	Prices on request
2,00...12,90	0,1	G	≤ 7,5 mm Ø 650 max	
4,00...13,90	0,1	C	> 7,5 mm Ø 1000 max	
13,00...16,00 14,00...22,00	1,0 0,5	G C	1000 max	

Tool material: solid carbide/K15

Surface finish: 

Standard-head lengths (mm)

Ø-range	length	Ø-range	length
2,00...2,49	15	10,00...10,99	35
2,50...2,99	18	11,00...17,00	40
3,00...3,99	20	17,01...20,00	45
4,00...5,19	25	20,01...23,00	50
5,20...6,99	30	23,01...26,00	55
7,00...9,99	35	26,01...40,00	65

Flute length: min. 20 x D

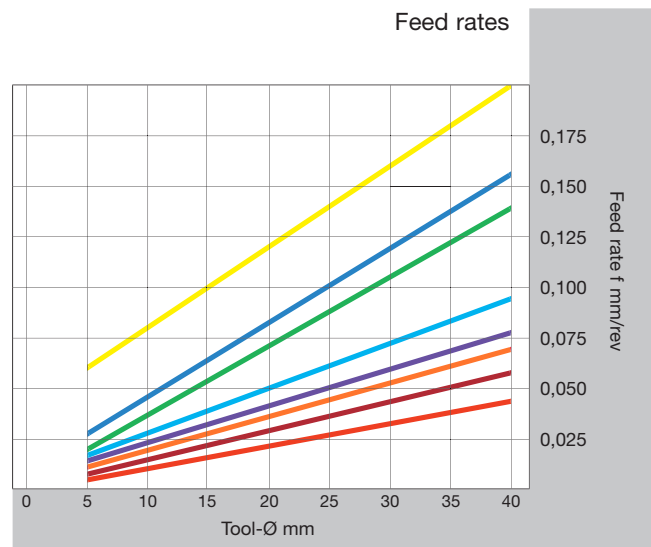
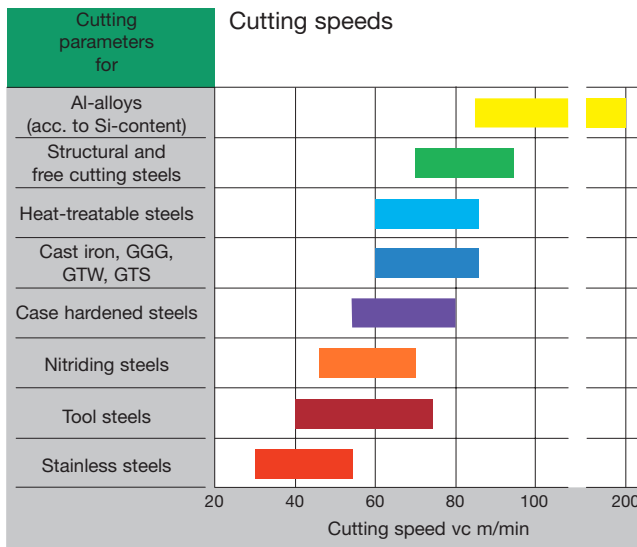

(Detailed cutting parameters see pages 22/23)

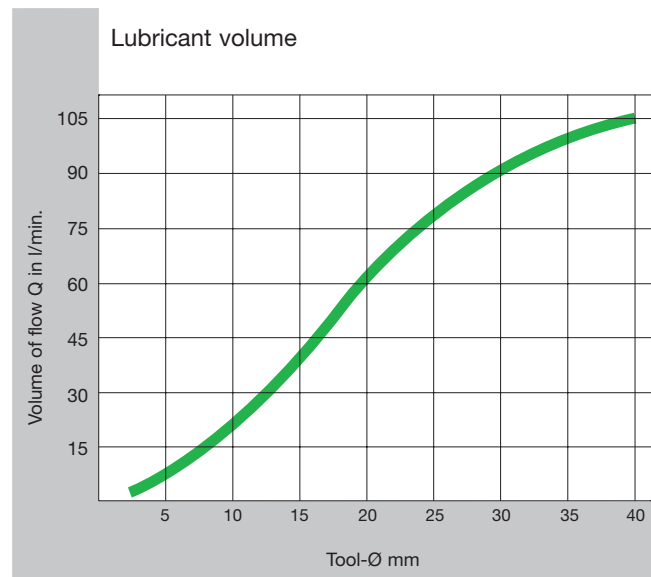
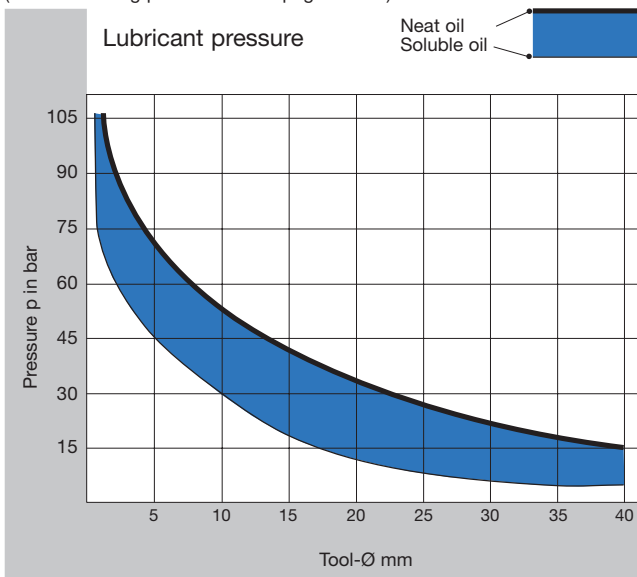

TWO-FLUTED GUN DRILLS WITH SOLID CARBIDE HEAD Z 80



suitable for cast iron, aluminium and short-chipping nonferrous metals, from \varnothing 6.0 - 27.0 mm, max. total length 1000 mm

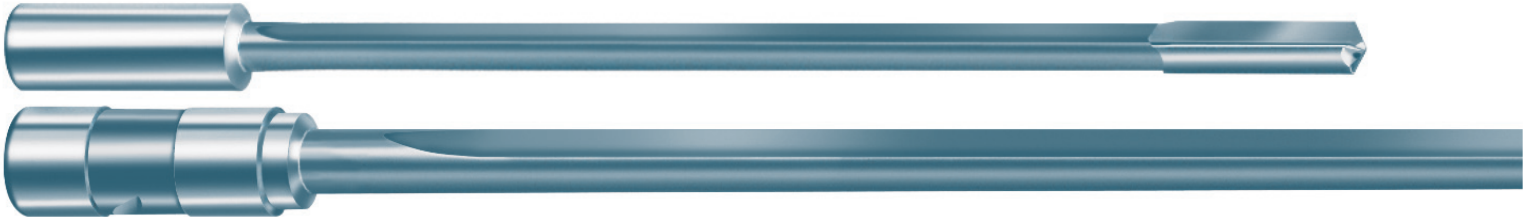

To ask for or to order Hartner two-fluted gun drills Z 80 with solid carbide head especially suited to your application, please complete the fax inquiry on page 21.

M MolyGlide

For certain materials a coating is required, as the successful application of gun drills with a bright surface finish cannot be guaranteed. For chilled cast iron and Al cast alloys with a Si-content above 10% we recommend our MolyGlide-coating. However, two-fluted gun drills can only be coated with MolyGlide up to an overall length of maximum 500 mm due to the technical production process. See Page 22/23.

The main advantage of two-fluted gun drills compared to single-fluted gun drills is the substantially higher feed rate that can be applied during the production of the hole. This is due to the design of the two-fluted gun drill, it has two cutting edges and two flutes. Holes can therefore be produced considerably faster. However, this increase in machining speed is combined with a reduction in hole accuracy. This is also a direct consequence

of a drill design with two cutting edges. As the cutting edges are positioned opposite each other, there is less of a smoothing effect and less support in comparison to a single-fluted gun drill. For drilling depths $\leq 10 \times D$ we recommend our TS Drill TS 150 GG, available ex stock and more cost-effective for these drilling depths than brazed gun drills. In addition, TS 150 GG does not require a pilot hole in most applications.

The dimensions required to calculate the length for conventional machine tools

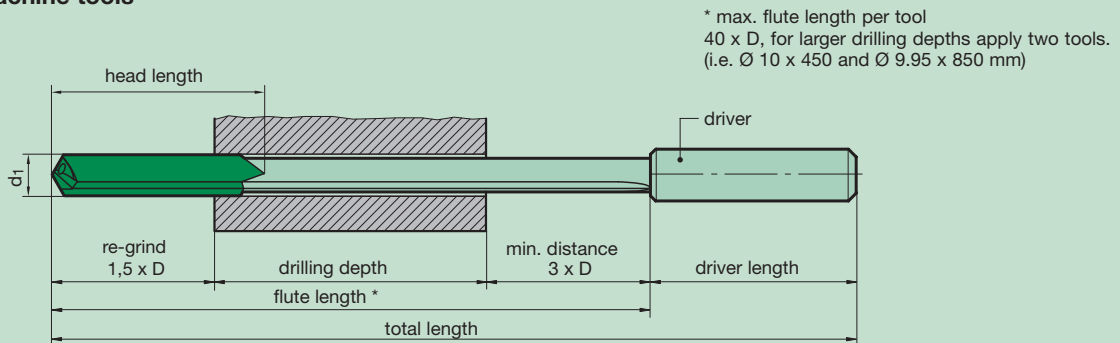

Standard point grinds

(special point grinds available)

Point grind G for machining cast iron

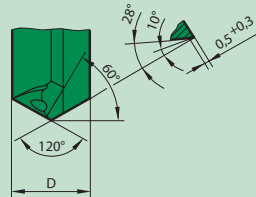

Point grind A for machining aluminium

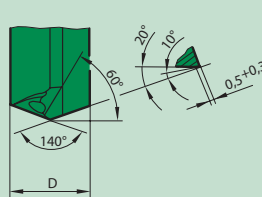

Point grind with chip breaker and chip splitter

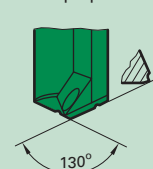



Tool material	Sol. carbide head
Carbide grade	K15
Hartner number	89508
Discount group	123
Surface finish	○

Drilling depth up to 30 x D

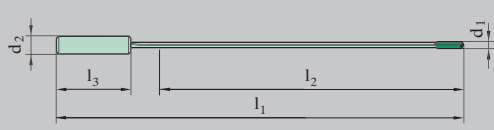

nom. Ø	driver Ø	total length	flute length	driver length
d1 h5	d2	l1	l2	l3
8.00	16	330	282	48
10.00	20	390	340	50
12.00	20	450	400	50

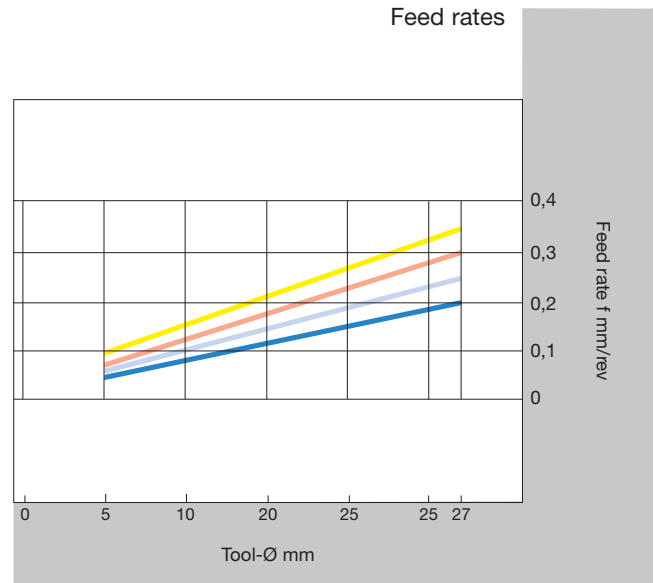
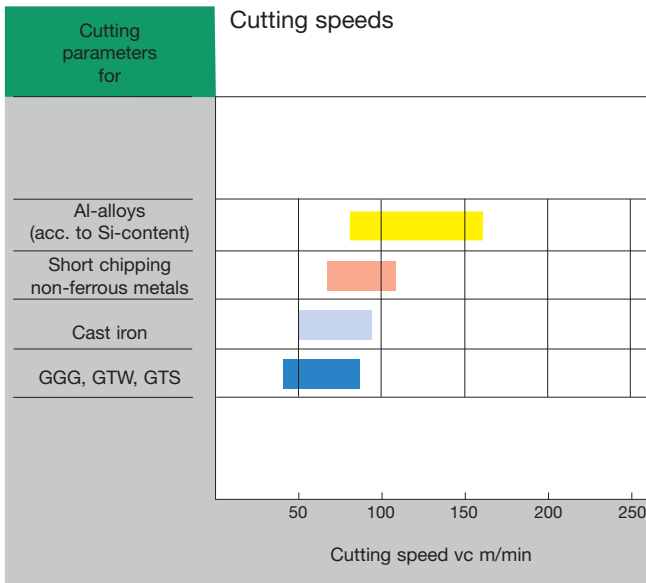
(Detailed cutting parameters see pages 22/23)



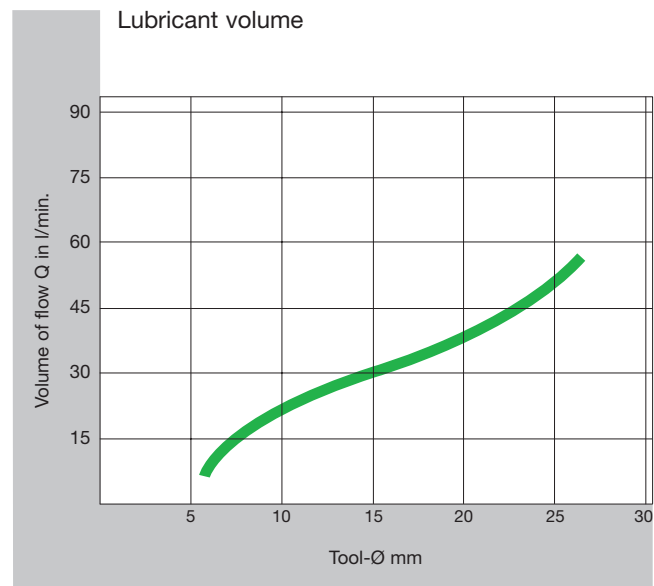
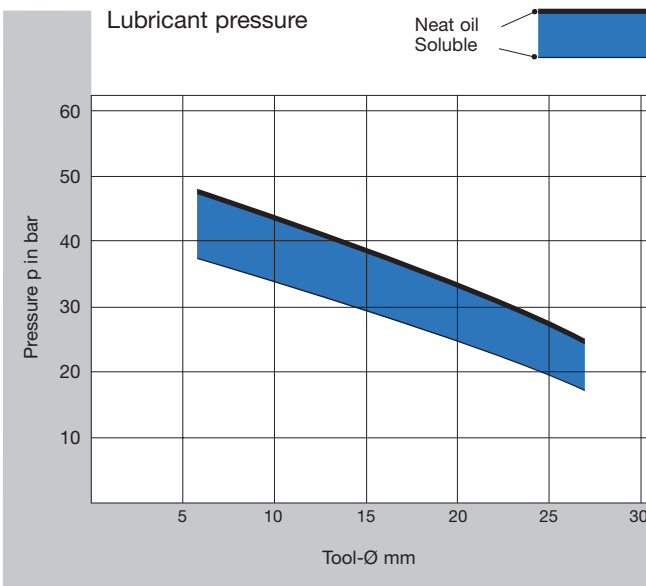

SINGLE-FLUTED GUN DRILLS E 800

with interchangeable inserts and supporting strips,
suitable for almost all materials, from \varnothing 16.0 - 40.0 mm,
max. total length 3000 mm

The interchangeable component technology for inserts and supporting strips makes any combination of carbide grade and coating possible.

The precision interchangeable inserts and supporting strips eliminate complicated adjustments.

The precision supporting strips are produced in Hartner carbide for your individual deep drilling task. They can be reverse-fitted, providing double tool life. In addition, they can be provided with any of the Hartner coatings.

Thanks to the precision insert seatings and the interchangeable inserts there is only a small number of interchangeable components. The tool is therefore extremely rigid.

Expensive stoppages are eliminated because the worn components can be replaced without removing the tool from the machine.

The expensive re-grinding process is eliminated thanks to the interchangeable insert technology.

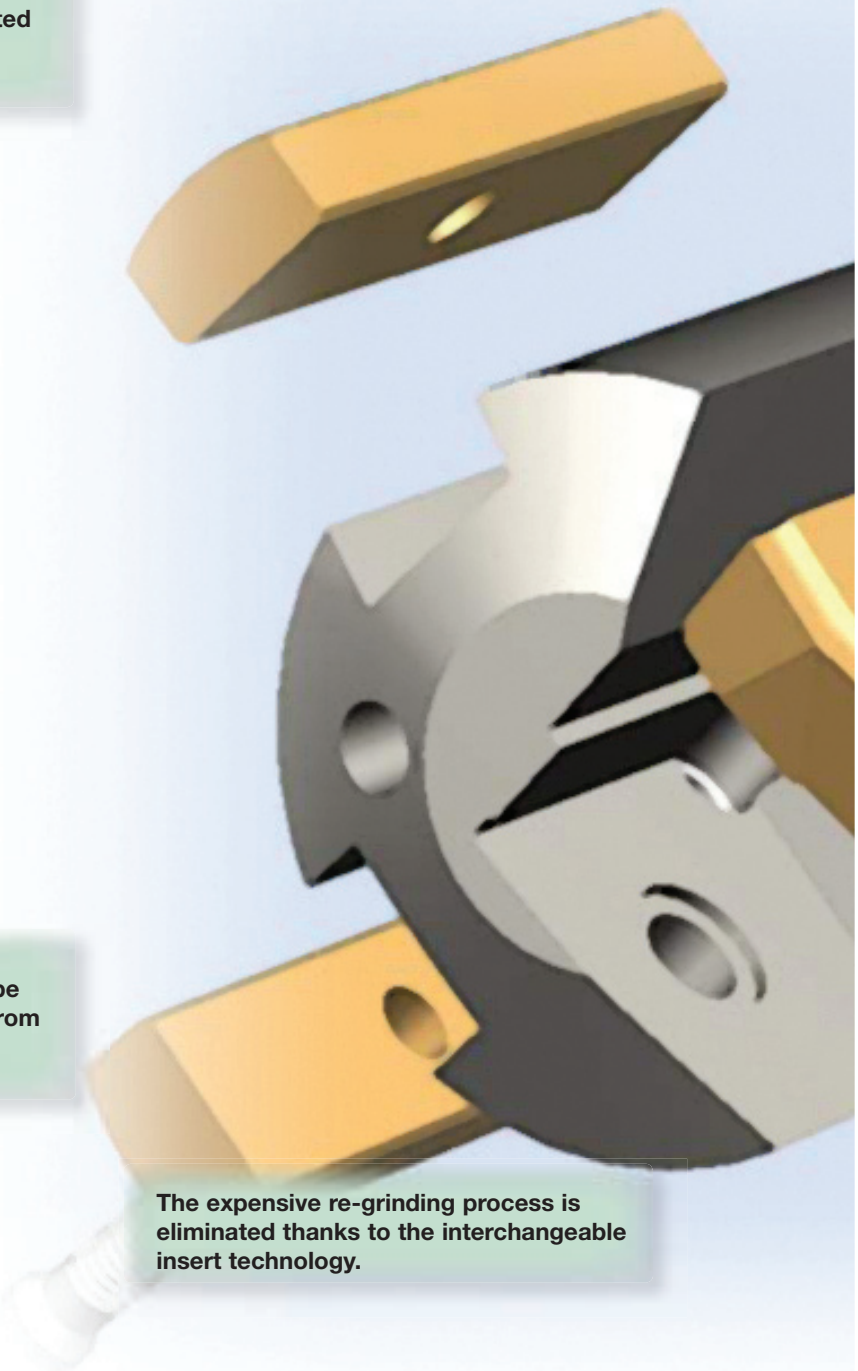

The driver is produced in heat-treatable steel to:

- DIN 6535 HA
- DIN 6535 HB
- DIN 6535 HE
- DIN 1835 E

All the forms generally required for deep drilling machines are possible.

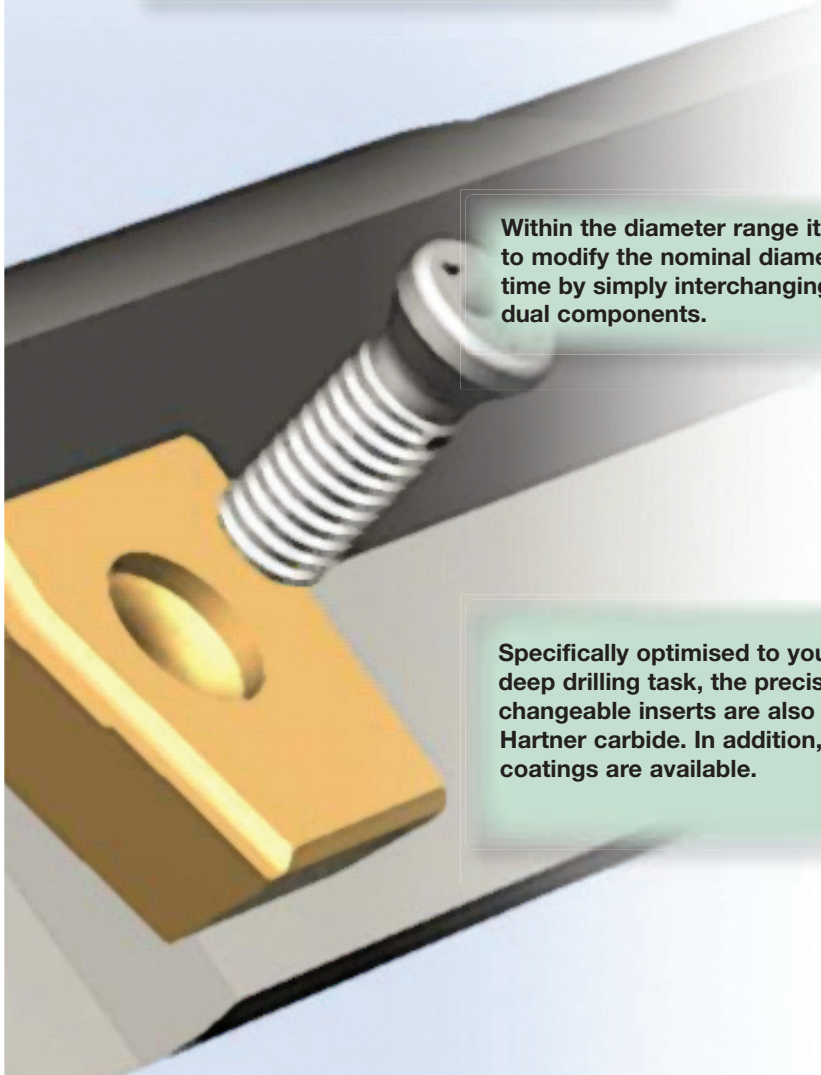

Within the diameter range it is possible to modify the nominal diameter at any time by simply interchanging the individual components.

Specifically optimised to your individual deep drilling task, the precision interchangeable inserts are also produced in Hartner carbide. In addition, all Hartner coatings are available.

The application orientated selection of the most suitable interchangeable insert always ensures optimal chip breaking – even in problematic materials.

Size	Diameter range (mm)
1.00	16.00 - 16.49
1.01	16.50 - 16.99
1.02	17.00 - 17.49
1.03	17.50 - 17.99
1.04	18.00 - 18.49
1.05	18.50 - 18.99
1.06	19.00 - 19.49
1.07	19.50 - 19.99
2.00	20.00 - 20.49
2.01	20.50 - 20.99
2.02	21.00 - 21.49
2.03	21.50 - 21.99
2.04	22.00 - 22.49
2.05	22.50 - 22.99
2.06	23.00 - 23.49
2.07	23.50 - 23.99
2.08	24.00 - 24.49
2.09	24.50 - 24.99
2.10	25.00 - 25.49
2.11	25.50 - 25.99
3.00	26.00 - 26.49
3.01	26.50 - 26.99
3.02	27.00 - 27.49
3.03	27.50 - 27.99
3.04	28.00 - 28.49
3.05	28.50 - 28.99
3.06	29.00 - 29.49
3.07	29.50 - 29.99
4.00	30.00 - 30.49
4.01	30.50 - 30.99
4.02	31.00 - 31.49
4.03	31.50 - 31.99
4.04	32.00 - 32.49
4.05	32.50 - 32.99
4.06	33.00 - 33.49
4.07	33.50 - 33.99
5.00	34.00 - 34.49
5.01	34.50 - 34.99
5.02	35.00 - 35.49
5.03	35.50 - 35.99
5.04	36.00 - 36.49
5.05	36.50 - 36.99
5.06	37.00 - 37.49
5.07	37.50 - 37.99
6.00	38.00 - 38.49
6.01	38.50 - 38.99
6.02	39.00 - 39.49
6.03	39.50 - 40.00

Every tool can be modified within the diameter range

SINGLE-FLUTED GUN DRILLS E 800

with interchangeable inserts and supporting strips, suitable for almost all materials, from \varnothing 16.0 - 40.0 mm, max. total length 3000 mm

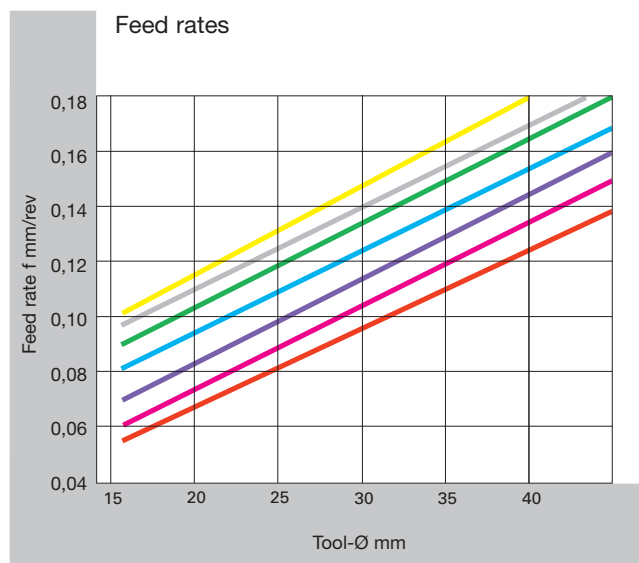
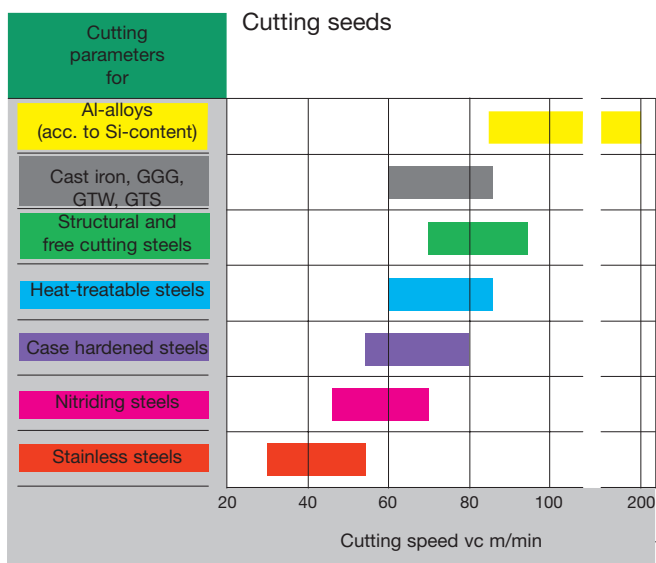
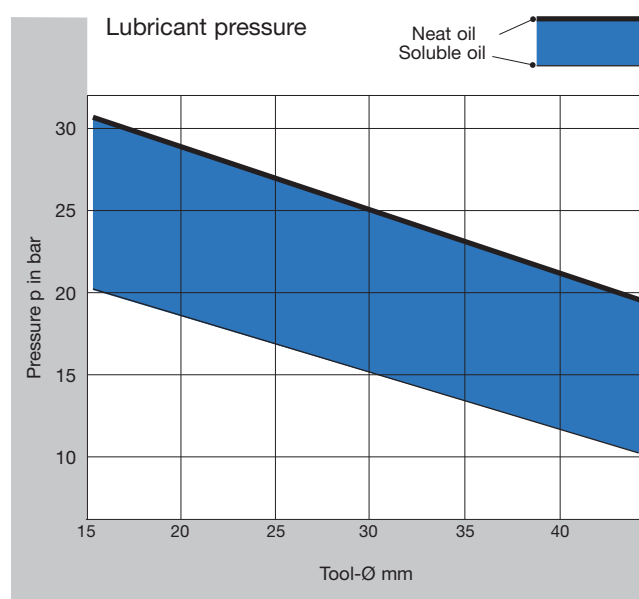
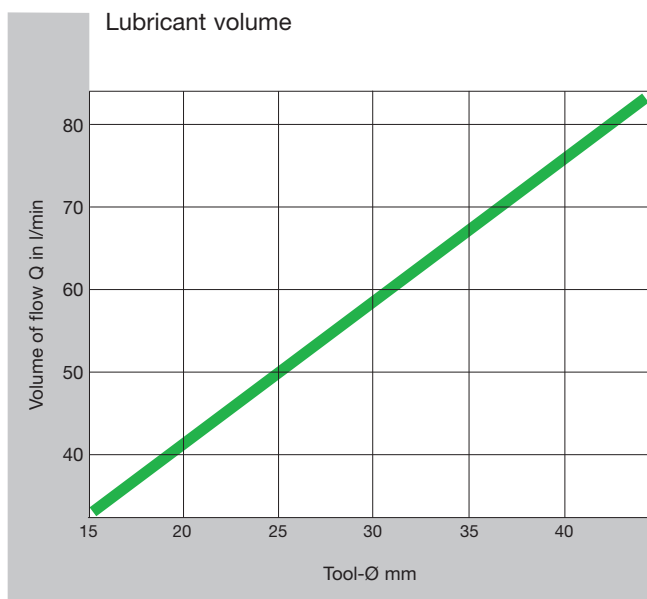

FAX INQUIRY / ORDER GUN DRILL

simply photo-copy, complete and fax...

Hartner GmbH
P.O. Box 10 04 27
D-72425 Albstadt
Telephone: +49 74 31/1 25-0
Fax: +49 74 31/1 25-5 47

Customer name and address: _____ _____ _____ _____	Contact name: _____ _____ _____ _____
---	--

Workpiece	Material: _____	Hole diameter: _____	Surface quality required: _____
	Description: _____	Tolerance on diameter: _____	Protruding edge: No Yes mm
	Quantity/Year: _____	Drilling depth: _____	Additional information: _____

Machine	Machining centre: _____	Deep drilling machine: _____	Coolant/lubrication: soluble oil neat oil
	Tool holder: _____	Tool holder: _____	Pressure: _____ bar
	No. of spindles: _____	No. of spindles: _____	Volume: _____ l/min

The Hartner E 800 for your application

Attention: - shortest flute length 15 x D
- achievable tolerance on IT9/IT10

Drawing, all Hartner nos. and specifications included with every quote.

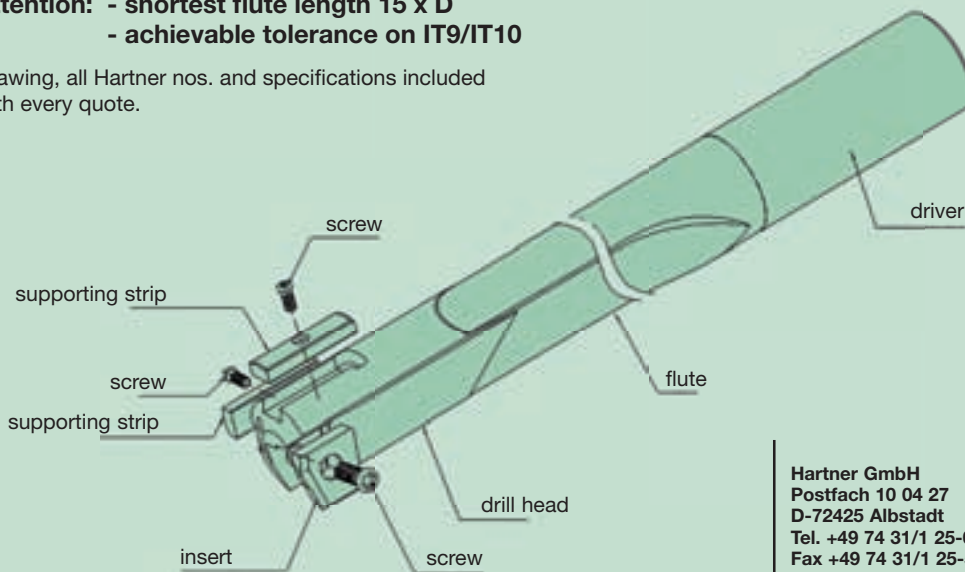

Hartner GmbH
Postfach 10 04 27
D-72425 Albstadt
Tel. +49 74 31/1 25-0
Fax +49 74 31/1 25-5 47

Gun Drill with interchangeable insert and supporting strip, internal cooling
Diameter range: 16.00 - 40.00mm

EX-STOCK RANGE SINGLE-FLUTED SOLID CARBIDE GUN DRILLS E 100

Tool material	Sol. Carb.
Carbide grade	K15
Hartner no.	89503
Discount group	123
Surface finish	○

Flute length $l_2 = 45$ mm

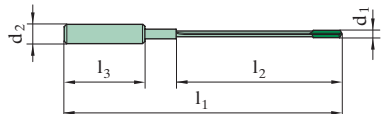

Diameter mm		Lengths mm		Availability
Nom. \varnothing d_1 h5	Driver d_2	Total length l_1	Driver l_3	
1.20	4.0	90	28	●
1.50	4.0	90	28	●
1.60	4.0	90	28	●
2.00	4.0	90	28	●
2.50	10.0	100	40	●
2.70	10.0	100	40	●
3.00	10.0	100	40	●
3.20	10.0	100	40	●

Tool material	Sol. Carb.
Carbide grade	K15
Hartner no.	89504
Discount group	123
Surface finish	○

Flute length $l_2 = 120$ mm

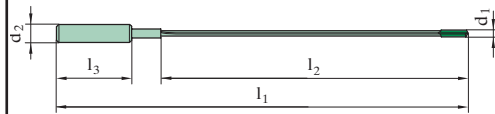

Diameter mm		Lengths mm		Availability
Nom. \varnothing d_1 h5	Driver d_2	Total length l_1	Driver l_3	
1.50	4.0	165	28	●
1.60	4.0	165	28	●
2.00	4.0	165	28	●
2.50	10.0	175	40	●
2.70	10.0	175	40	●
3.00	10.0	175	40	●
3.20	10.0	175	40	●
3.50	10.0	175	40	●
4.00	10.0	175	40	●
4.20	10.0	175	40	●
4.50	10.0	175	40	●
5.00	10.0	175	40	●

Tool material	Sol. Carb.
Carbide grade	K15
Hartner no.	89501
Discount group	123
Surface finish	○

Flute length $l_2 = 80$ mm

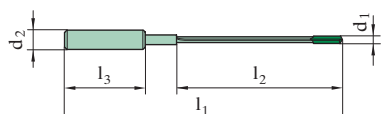

Diameter mm		Lengths mm		Availability
Nom. \varnothing d_1 h5	Driver d_2	Total length l_1	Driver l_3	
1.20	4.0	125	28	●
1.50	4.0	125	28	●
1.60	4.0	125	28	●
2.00	4.0	125	28	●
2.50	10.0	135	40	●
2.70	10.0	135	40	●
3.00	10.0	135	40	●
3.20	10.0	135	40	●
3.50	10.0	135	40	●
4.00	10.0	135	40	●
4.20	10.0	135	40	●
4.50	10.0	135	40	●
5.00	10.0	135	40	●

Tool material	Sol. Carb.
Carbide grade	K15
Hartner no.	89502
Discount group	123
Surface finish	○

Flute length $l_2 = 160$ mm

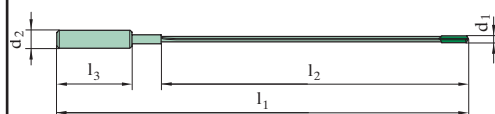

Diameter mm		Lengths mm		Availability
Nom. \varnothing d_1 h5	Driver d_2	Total length l_1	Driver l_3	
1.50	4.0	205	28	●
1.60	4.0	205	28	●
2.00	4.0	205	28	●
2.50	10.0	215	40	●
2.70	10.0	215	40	●
3.00	10.0	215	40	●
3.20	10.0	215	40	●
3.50	10.0	215	40	●
4.00	10.0	215	40	●
4.20	10.0	215	40	●
4.50	10.0	215	40	●
5.00	10.0	215	40	●

Delivery: Hartner nos. 89501/89502/89503/89504 supplied within 24 hours. With driver to DIN 6535 from HB or HE supplied within 10 working days. Special dimensions available on request.

EX-STOCK RANGE SINGLE-FLUTED GUN DRILLS SOL. CARB. HEAD E 80

Tool material	Sol. carbide head
Carbide grade	K15
Hartner no.	89505
Discount group	123
Surface finish	T

for drilling depths up to 20 x D

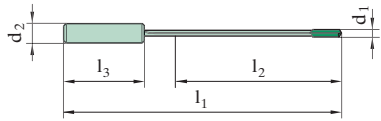

Diameter mm		Lengths mm			Availability
Nom. Ø d1 h5	Driver d2	Total length l1	Flute length l2	Driver l3	
4.00	12	150	100	45	●
4.20	12	160	110	45	●
4.50	12	170	120	45	●
5.00	16	180	130	48	●
5.50	16	190	140	48	●
6.00	16	210	160	48	●
6.50	16	220	170	48	●
7.00	16	235	185	48	●
8.00	16	260	210	48	●
9.00	16	280	230	48	●
10.00	20	320	260	50	●
12.00	20	370	310	50	●



Preparation: always produce a pilot hole (~1,5 x D).

Tool material	Sol. carbide head
Carbide grade	K15
Hartner no.	89509
Discount group	123
Surface finish	T

for drilling depths up to 30 x D

Diameter mm		Lengths mm			Availability
Nom. Ø d1 h5	Driver d2	Total length l1	Flute length l2	Driver l3	
4.00	12	200	155	45	●
4.20	12	210	165	45	●
4.50	12	220	175	45	●
5.00	16	230	182	48	●
5.50	16	245	197	48	●
6.00	16	260	212	48	●
6.50	16	275	227	48	●
7.00	16	290	242	48	●
8.00	16	320	272	48	●
9.00	16	350	302	48	●
10.00	20	400	350	50	●
12.00	20	450	400	50	●



Preparation: always produce a pilot hole (~1,5 x D).

Tool material	Sol. carbide head
Carbide grade	K15
Hartner no.	89506
Discount group	123
Surface finish	T

for drilling depths up to 40 x D

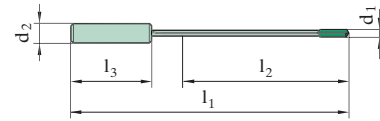

Diameter mm		Lengths mm			Availability
Nom. Ø d1 h5	Driver d2	Total length l1	Flute length l2	Driver l3	
4.00	12	230	185	45	●
4.20	12	240	195	45	●
4.50	12	250	205	45	●
5.00	16	280	232	48	●
5.50	16	300	252	48	●
6.00	16	320	272	48	●
6.50	16	340	292	48	●
7.00	16	370	322	48	●
8.00	16	420	372	48	●
9.00	16	450	402	48	●
10.00	20	510	460	50	●
12.00	20	600	550	50	●



Preparation: always produce a pilot hole (~1,5 x D).

Tool material	Sol. carbide head
Carbide grade	K15
Hartner no.	89507
Discount group	123
Surface finish	T

for drilling depths up to 80 x D

Diameter mm		Lengths mm			Availability
Nom. Ø d1 h5	Driver d2	Total length l1	Flute length l2	Driver l3	
4.95	16	480	432	48	●
5.95	16	560	512	48	●
7.95	16	740	692	48	●
9.95	20	910	860	50	●
11.95	20	1080	1030	50	●



Preparation: always apply Hartner no. 89506 up to 40 x D before.

DRIVERS

Attachments

The range of drivers introduced below is available ex stock. However, it only represents a small selection of drivers from our complete range. We naturally also produce individual drivers of

the highest precision to customer drawings. **Attention! Single-fluted solid carbide gun drills** require drivers with positioning lugs. Further information on request.

Drivers for deep hole drilling machines

1

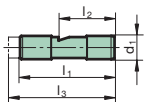

code no.	d ₁	l ₁	l ₂	l ₃
1.1	10	40	24	-
1.2	10	40	24	45
1.3	10	40	24	55
1.4	16	45	31,2	-
1.5	25	70	34	-
1.6	25	70	34	78

2

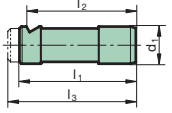

code no.	d ₁	l ₁	l ₂	l ₃
2.1	16	50	47	-
2.2	16	50	47	55
2.3	16	50	47	70

3

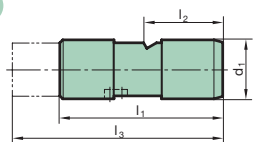

code no.	d ₁	l ₁	l ₂	l ₃
3.1	25	70	34	100



Accessories for deep hole drilling machines
 In contrast to conventional machine tools, certain accessories, i.e. drilling bushes, seal discs, steady rest bushings etc., are part of the standard equipment on deep hole drilling machines. A selection of these products are shown above. Because of the multitude of accessories currently available, it is impossible to list tables with dimensions for each item in this brochure. However, we can supply most of products generally applied on request (with drawing if possible).

4

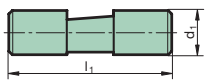

code no.	d ₁	l ₁
4.1	19,05	70

5

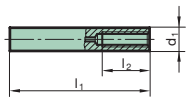

code no.	d ₁	l ₁	l ₂
5.1	10	60	20
5.2	16	80	28
5.3	25	100	50

6

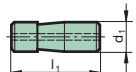

code no.	d ₁ (inch)	l ₁
6.1	1/2	38
6.2	3/4	70

7

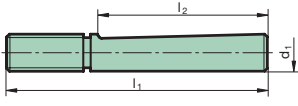

code no.	d ₁	l ₁	l ₂
7.1	16	112	73
7.2	20	126	82

Drivers to DIN 1835

9 Form E

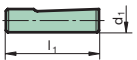

code no.	d ₁	l ₁
9.1	8	36
9.2	10	40
9.3	12	45
9.4	16	48
9.5	20	50
9.6	25	56
9.7	32	60

Drivers to DIN 6535

10 Form HA

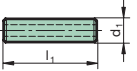

code no.	d ₁	l ₁
10.1	8	40
10.2	10	40
10.3	12	45
10.4	16	48
10.5	20	50
10.6	25	56
10.7	32	60

8 Form HB

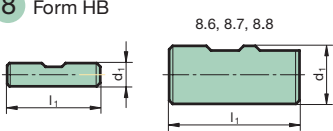

code no.	d ₁	l ₁
8.1	8	36
8.2	10	40
8.3	12	45
8.4	16	48
8.5	20	50
8.6	25	56
8.7	32	60
8.8	40	70

11 Form HE

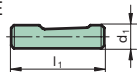

code no.	d ₁	l ₁
11.1	8	36
11.2	10	40
11.3	12	45
11.4	16	48
11.5	20	50

Drivers to VDI draft

12

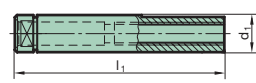

code no.	d ₁	l ₁
12.1	10	68
12.2	16	90
12.3	25	112

Drivers to Speed-Bit-System

13

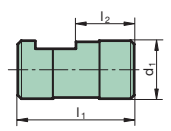

code no.	d ₁	l ₁	l ₂
13.1	16	40	16
13.2	25	50	25

ADDITIONAL TECHNICAL PARAMETERS

Special point grinds for single-fluted gun drills

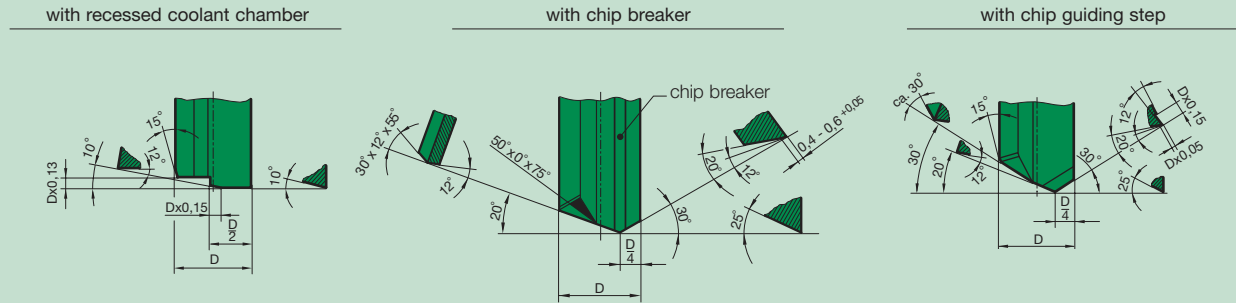

Backtaper ratio for gun drills

(dimensions in mm)

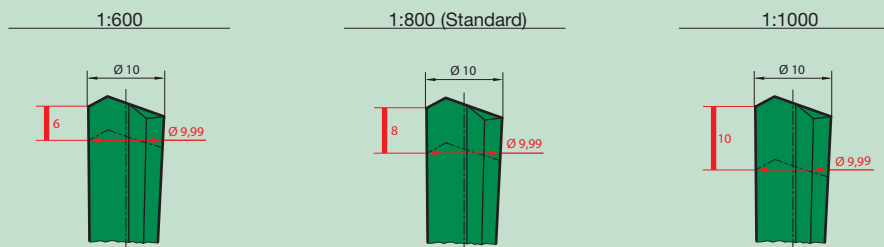

Variations for drivers at gun drills with tube shank

Solution for $\text{nom.-}\varnothing < \text{driver-}\varnothing$
(difference must be appr. 6 mm):
tube shank installed in driver

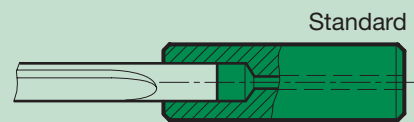

Solution for $\text{nom.-}\varnothing - \text{driver-}\varnothing$
(close to parallel):
tube shank installed over collar

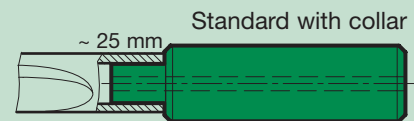

Solution for $\text{nom.-}\varnothing > \text{driver-}\varnothing$:
tube shank installed over collar,
inside- \varnothing of tube shank $>$ driver- \varnothing ,
tube shank fits against flange shoulder.

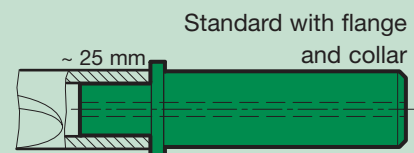

GRINDING EQUIPMENT FOR GUN DRILLS

TBM 116

TBM 116 is a manually operated, universal grinding machine. Its compact design combined with Hartner's single-fluted gun drill grinding system and Hartner's double grinding wheel makes this a perfect unit to re-grind single-fluted gun drills. It is especially suitable for the re-grinding of a small to medium number of items of varying diameters and lengths. Furthermore, it also allows the fairly simple addition of transverse chip breakers to single-fluted gun drills as well as other modifications.

Supplied items:

Grinding machine with two high-powered light units as well as two 220 V sockets (grinding system and grinding wheel not included)

Machine data:

Input power requirements 380 V/50 Hz, Grinding wheel 2850 rev./min, Max. diameter of grinding wheel 150 mm



TBV 116

The fixture is designed for the re-grinding of single-fluted gun drills in the diameter range from 3 mm to 30 mm. It is ideally suitable for standard and special point grinds. A minimum flute length is of no importance thanks to a short center sleeve. In addition, the fixture is supplied with a supporting bar for long tools. TBV 116 is therefore truly universal and can be applied on any commercial, manual tool grinding machine.

For the use with TBV 116 we recommend our double grinding wheel DSS 125.

Attention:

Single-fluted gun drills have a flute spacing angle of 120° and can therefore not be clamped in a collet in a separate unit. You could possibly destroy the tool.



TBV 216

The new TBV 216 universal grinding fixture for small diameter single-fluted gun drills from 1.0 to 6.0 mm and a maximum length of 350 mm is simple to handle and enables the re-grinding or modifying of single-fluted gun drills in only four operations. Grinding is achieved with a 3-axis swivel mechanism, enabling the grinding of various point angles. It is possible to adjust and if necessary correct any angle individually.

We recommend the application of our single grinding wheel ESS 125.

To include:

- A set of guide bushes with the diameters 1.0 / 1.5 / 2.0 / 2.5 / 3.0 / 3.5 mm
- Various adaptors
- Centering microscope
- Spotlight and magnifier



FAX INQUIRY / ORDER

simply photo-copy, complete and fax...

Hartner GmbH
 P.O. Box 10 04 27
 D-72425 Albstadt
 Telephone +49 74 31/1 25-0
 Fax +49 74 31/1 25-5 47

Deep hole gun drill:

E 100 Single-fluted solid carbide gun drill

E 80 Single-fluted gun drill with solid carbide head

Z 80 Two-fluted gun drill with sol. carb. head

Head form: _____

Number required: _____ items

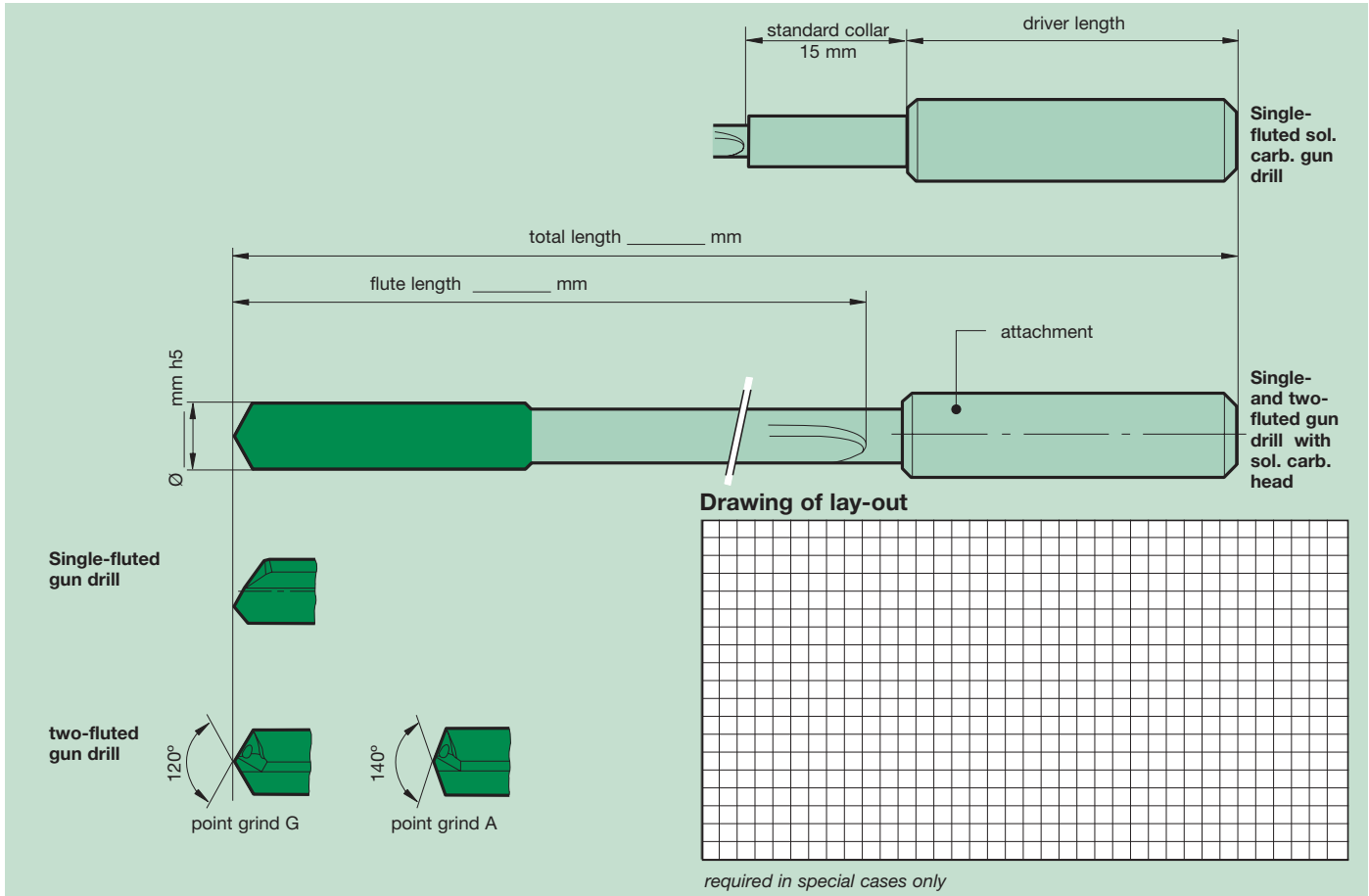

Driver: no code no.: _____ to enclosed drawing

Coating: TiN FIRE MolyGlide TiAlN _____

Workpiece: drilling depth: _____ hole tolerance: _____ material: _____

blind hole through hole transverse hole

Machine type: deep hole drilling machine conventional machine tool

Coolant: deep drilling oil soluble oil

pressure _____ bar pressure _____ bar

Company: _____ **Company stamp:** _____

Telephone/Fax: _____ **Signature:** _____

Contact: _____

APPLICATION RECOMMENDATIONS FOR GUN DRILLS

Drill Ø mm from	Feed column no.							
	11	12	13	14	15	16	17	18
	f (mm/rev)							
1.50	0.002	0.004	0.006	0.008	0.012	0.020	0.032	0.045
2.00	0.003	0.005	0.007	0.010	0.016	0.028	0.046	0.055
2.50	0.004	0.006	0.008	0.012	0.018	0.030	0.054	0.070
4.00	0.005	0.007	0.010	0.016	0.025	0.043	0.065	0.085
6.00	0.007	0.009	0.013	0.024	0.035	0.061	0.085	0.120
8.00	0.010	0.014	0.022	0.032	0.045	0.068	0.100	0.150
10.00	0.012	0.016	0.028	0.040	0.055	0.075	0.120	0.180
14.00	0.020	0.025	0.035	0.050	0.065	0.085	0.130	0.180
18.00	0.025	0.030	0.040	0.055	0.070	0.095	0.145	0.200
20.00	0.026	0.035	0.045	0.060	0.080	0.110	0.180	0.250
24.00	0.027	0.036	0.047	0.065	0.085	0.130	0.185	0.300
28.00	0.028	0.038	0.049	0.068	0.090	0.140	0.195	0.350
30.00	0.030	0.040	0.050	0.070	0.100	0.150	0.200	0.400
35.00	0.035	0.045	0.055	0.075	0.120	0.180	0.250	0.450
40.00	0.040	0.050	0.060	0.080	0.150	0.200	0.300	0.500

*The feed rates always relate to tools with the recommended coating. In some cases the successful application of uncoated tools cannot be guaranteed.

Surface finish:

- bright
- TiN-coated
- TiAlN-coated
- TiCN-coated
- FIRE-coated
- MolyGlide®-coated

Material dependent coolants

- soluble oil
- neat oil
- air
- suitable for minimum quantity lubrication

Cutting parameters can be reduced if cooling parameters are insufficient. Pressure increase systems are also an option.



Gun drills must be guided during spot-drilling. Gun drills must never operate at full speed without support in the machine shop.

The sequence of operations for deep hole drilling

- production of pilot hole (L = 1.5 x D)
- enter at low revolutions, approx. 200 rev./min, feed rate approx. 500 mm/min
- setting of coolant pressure and revolutions
- uninterrupted drilling to required drilling depth without wood pecking.
- When applying gun drills with increased length-diameter-ratio (e.g. single-fluted solid carbide gun drills from flute length 160 mm), we recommend machining with reduced cutting parameters (approx. 75% of the optimal cutting speed) up to a drilling depth of approx. 25 mm.
- switching off coolant supply after reaching the required hole depth
- withdrawal in top gear with stationary spindle

Material group	Material examples <i>Figures in bold = material no. to DIN EN 10 027</i>	Tens. strength Hard- N/mm ² ness	Cool- ant
Common structural steels	1.0035 S185, 1.0486 StE P275N, 1.0345 P235GH, 1.0425 P265GH 1.0050 E295, 1.0070 E360, 1.8937 P500NH	≤500 >500-850	● ●
Free-cutting steels	1.0718 11SMnPb30, 1.0736 115Mn37 1.0727 46 S20, 1.0728 60 S20, 1.0757 46SPb20	≤850 850-1000	● ●
Unalloyed heat-treatable steels	1.0402 C22, 1.1178 C30E 1.0503 C45, 1.1191 C45E 1.0601 C60, 1.1221 C60E	≤ 700 700-850 850-1000	● ● ●
Alloyed heat-treatable steels	1.5131 50MnSi4, 1.7003 38Cr2, 1.7030 28Cr4 1.5710 36NiCr6, 1.7035 41Cr4, 1.7225 42CrMo4	850-1000 1000-1200	● ●
Unalloyed case hardened steels	1.0301 C10, 1.1121 C10E	≤750	●
Alloyed case hardened steels	1.7043 38Cr4 1.5752 14NiCr14, 1.7131 16MnCr5, 1.7264 20CrMo5	850-1000 1000-1200	● ●
Nitriding steels	1.8504 34CrAl6 1.8519 31CrMoV9, 1.8550 34CrAlNi7	≥850-1000 1000-1200	● ●
Tool steels	1.1750 C75W, 1.2067 102Cr6, 1.2307 29CrMoV9 1.2080 X210Cr12, 1.2083 X42Cr13, 1.2419 105WCr6, 1.2767 X45NiCrMo4	≤850 850-1000	● ●
High speed steels	1.3243 S 6-5-2-5, 1.3343 S 6-5-2, 1.3344 61CrV4	≥650-1000	●
Spring steels	1.5026 55Si7, 1.7176 55Cr3, 1.8159 51CrV4	≤330 HB	●
Stainless steels, sulphured austenitic martensitic	1.4005 X12CrS13, 1.4104 X14CrMoS17, 1.4105 X6CrMoS17 1.4301 X5CrNi18 10, 1.4541 X6CrNiTi18 10, 1.4571 X6CrNiMoTi 17 12 2 1.4057 X17CrNi16-1, 1.4122 X39CrMo17-1, 1.4521 X2CrMoTi18 2	≤850 ≤850 ≤850	● ● ●
Hardened steels	-	≤40-48 HRC >48-60 HRC	● ●
Special alloys	Nimonic, Inconel, Monel, Hastelloy	≤1200	●
Cast iron	EN-GJL-100 ... EN-GJL-200 EN-GJL-250 ... EN-GJL-350	≤240 HB ≤300 HB	● ●
Spheroidal graphite iron and malleable cast iron	EN-GJMW-350-4, EN-GJMB-550-4, EN-GJS-500-7 EN-GJMB-700-2, EN-GJS-700-2	≤240 HB ≤300 HB	● ●
Chilled cast iron	-	≤350 HB	●
Ti and Ti alloys	3.7024 Ti99.5, 3.7114 TiAl5Sn2.5, 3.7124 TiCu2 3.7154 TiAl6Zr5, 3.7164 TiAl6V4, 3.7184 TiAl4Mo4Sn2.5, - TiAl8Mo1V1	≤850 850-1200	● ●
Aluminium and Al-alloys	3.0255 Al99.5, 3.2315 AlMgSi1, 3.3515 AlMg1	≤400	●
Al-wrought alloys	3.0615 AlMgSiPb, 3.1325 AlCuMg1, 3.3245 AlMg3Si	≤450	●
Al-cast alloys ≤ 10 % Si > 10 % Si	3.2131 G-AlSi5Cu1, 3.2153 G-AlSi7Cu3, 3.2573 G-AlSi9 3.2581 G-AlSi12, 3.2583 G-AlSi12Cu, - G-AlSi12CuNiMg	≤600 ≤600	● ●
Magnesium-alloys	MgMn2, G-MgAl8Zn1, G-MgAl6Zn3	≤450	○
Copper, low alloyed	2.0070 SE-Cu, 2.1020 CuSn6, 2.1096 G-CuSn5Zn2Pb	≤400	●
Brass, short-chipping long-chipping	2.0380 CuZn39Pb2, 2.0401 CuZn39Pb3, 2.0410 CuZn43Pb2 2.0250 CuZn20, 2.0280 CuZn33, 2.0332 CuZn37Pb0.5	≤600 ≤600	● ●
Bronze, short-chipping	2.1090 CuSn7Zn2Pb, 2.1170 CuPb5Sn5, 2.1176 CuPb10Sn 2.0790 CuNi18Zn19Pb	≤600 >600-850	● ●
Bronze, long-chipping	2.0916 CuAl5, 2.0960 CuAl9Mn, 2.1050 CuSn10 2.0980 CuAl11Ni, 2.1247 CuBe2	≤850 850-1000	● ●
Duroplastics Thermoplastics	Bakelit, Resopal, Pertinax, Moltopren Plexiglas, Hostalen, Novodur, Makralon	-	○ ○
Kevlar Glass/carbon fibre.	Kevlar GFK/CFK	-	○ ○

Single-fl ut
carbide gu n



single-fluted

solid

1,2 ... 5

≤35xD

recom- mended coating*	v _c m/ min	Feed col. no.
	100	15
	85	15
	90	15
	80	15
	90	14
	80	14
	75	14
●	75	14
●	65	14
●	80	15
	75	14
	65	14
●	75	14
●	65	14
	55	12
	65	13
	55	14
	45	14
	35	14
	30	13
	25	10
	35	12
●	85	16
●	80	16
	80	15
	70	15
●	55	14
	35	12
	30	12
	150	17
	120	17
	150	18
	130	18
●	110	17
	75	15
	75	15
●	60	14
●	50	14

Hartner GmbH
P.O. box 10 04 27
D-72425 Albstadt
Tel. +49 74 31/1 25-0
Fax +49 74 31/1 25-5 47
www.hartner.de



HARTNER

Precision Cutting Tools